

Spindle Assembly

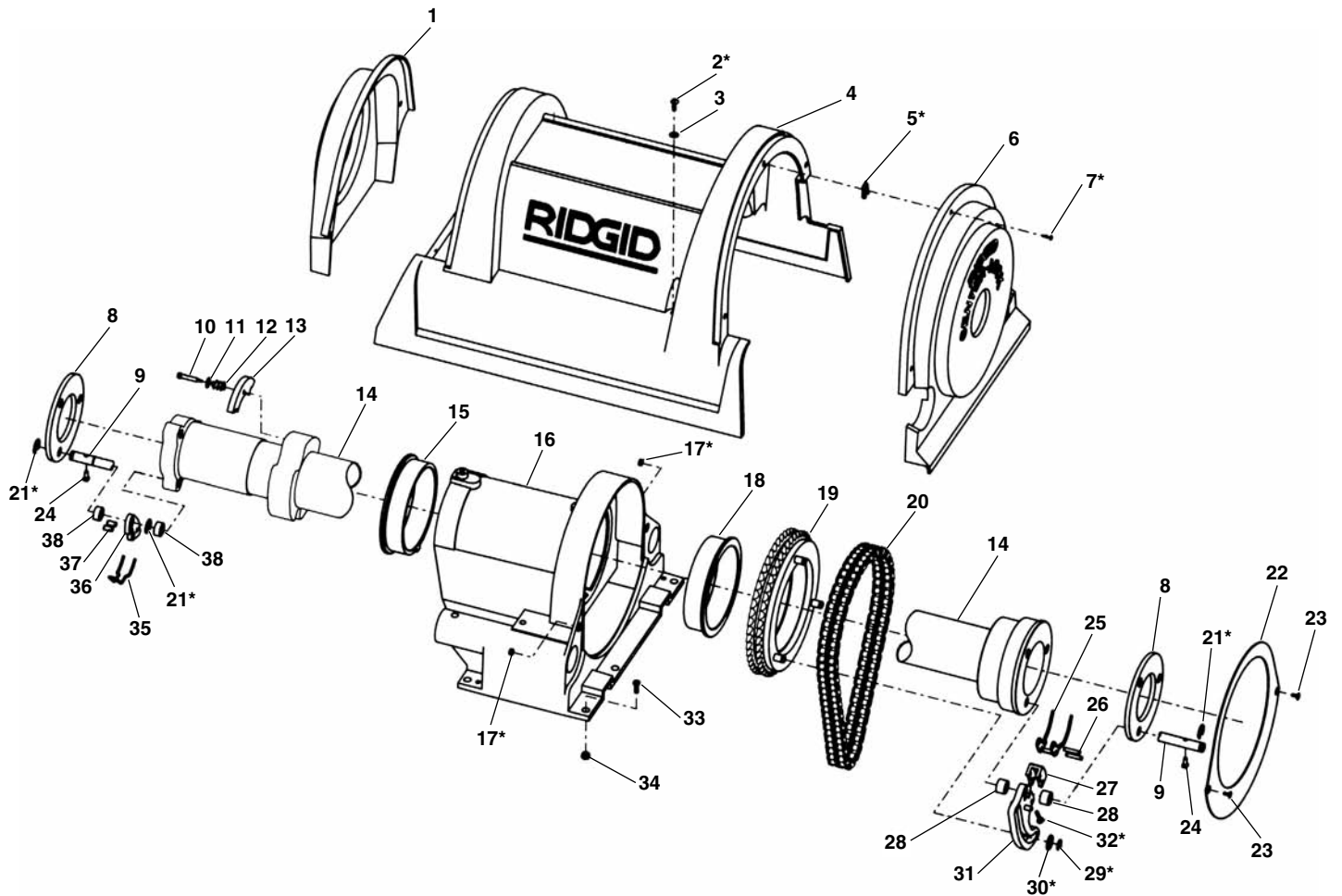

**NOTE: Order parts by Catalog Number only.
DO NOT order by Reference Number.**

Ref. No.	Catalog No.	Description	Ref. No.	Catalog No.	Description
1	34652	Rear Cover	21*	26937	Retaining Ring (9)
2*	43352	Screw (3)	22	34757	Splash Guard
3*	43357	Washer (3)	23*	46785	Screw 10-32 x 3/8" (2)
4	34657	Top Cover w/Clips (Includes 4, 5, 7)	24	34762	Pivot Rod Pin (6)
5*	43362	"J" Clip (6)	25	34772	Front Pick-up Springs (3)
6	34662	Front Cover	26	34777	Roll Pin (6)
7*	43367	Screw (6)	27	34782	Jaw Insert (3) (Includes Ref.# 25, 26)
8	47497	Pivot Rod Support (2)	28	34787	Front Jaw Spacer (6)
9	34767	Pivot Rod (3)	29*	34245	Retaining Ring (3)
10	39567	Shoulder Screw 1/4" -20 x 1 1/2" (3)	30*	34792	Washer (3)
11	54290	Flat Washer (3)	31	40847	Front Jaw (Includes Ref.# 25, 26, 27, 32)
12	35362	Spring (3)	32*	44557	Jaw Insert Screw (3)
13	34702	Brake Shoe (3)	33	45470	Bolt 3/8" - 16 x 1" (5)
14	44552	Spindle Tube	34	44225	Nut 3/8" - 16 (5)
15	34712	Rear Bearing	35	34807	Rear Pick-up Spring (3)
16	34717	Spindle Housing	36	41347	Rear Jaw Set (Includes Ref.# 35, 37)
17*	34722	Nut #10 (2)	37	34817	Pick-up Spring Pin (6)
18	34727	Front Bearing	38	34802	Rear Jaw Spacer (6)
19	34732	Drive Sprocket w/Pins	—	46727	Hardware package (Includes items marked with *)
20	34742	Drive Chain w/Master Link			
	34747	Master Link			

†See Service Notes